

TYPICAL IN SIZE OF SO MANY INDUSTRIAL PARK BUILDINGS FOUND THROUGHOUT CANADA, THE GREEN BUILDING QUALITIES AND ARCHITECTURAL MERIT OF THE ACCU-LIFT™ FLOORING SYSTEMS BUILDING SETS THE STANDARD FOR THE FUTURE [1]. THE EXTERIOR FINISHES OF CORRUGATED METAL AND CEMENT FIBREBOARD CONTRAST WITH THE WARM CEDAR FENCE SURROUNDING THE EMPLOYEE TERRACE [2]. FIXED LOUVERS HELP REDUCE HEAT GAIN FROM THE HIGH SUMMER SUN [3]. VIEW ALONG THE SOUTH, STREET-FACING FACADE [4].



## Acculift Office/Warehouse

# Modest building reflects philosophy of earth-friendly products

Christopher Simmonds

**Accu-Lift™ Flooring Systems in Ottawa sells and installs environmentally-friendly flooring. Its new 8,300sf retail store and warehouse has a bright, open and efficient work environment that showcases the company and its commitment to conservation principles.**

### ARCHITECT

Christopher Simmonds Architect, Ottawa [with Ted Landrun, Conrado Canolo, Frisina Leaning, and Alena Klimava]

### STRUCTURAL ENGINEER

Cleland, Jardine Engineering Ltd., Ottawa

### MECHANICAL AND ELECTRICAL ENGINEER

Leslie Jones & Associates, Ottawa

### CONSTRUCTION MANAGEMENT

RND Construction, Ottawa

### PHOTOS

Gordon King, Ottawa

Our firm designed the project in close collaboration with the building owner and construction manager who happened to be the same person, Roy Nandram. Roy is an Energy Star building contractor, and the proprietor of Accu-lift, a one-of-a-kind company that replaces old office carpet with new carpet tiles using an ingenious method of jacking up furniture and partitions rather than moving them, thus speeding up the installation and greatly reducing the client's downtime.

Accu-lift takes great care in removing and handling the old carpet so that it can be sent away for full recycling. His support of

recycling and his Energy Star building experience led to his wish for a new building with a healthy interior, low energy consumption, and minimal use of materials. While not LEED certified, we followed LEED principles in the design.

Every detail of the project, from schematic design to review of shop drawings for the sun shading devices, we coordinated with Roy whose expertise helped to shape the final result. Such scrupulous planning has achieved a 42% reduction in energy consumption below the Canadian National Energy Code, and received funding under the Canadian Building Incentive Program.

Nandram, mechanical engineer Les Jones, and I agreed that a green building must start with a well insulated envelope. Such an envelope helps to maintain a constant indoor temperature in all seasons, and consequently allows for smaller, generally less expensive HVAC equipment. For this project, Jones recommended high-efficiency [94%] Lennox residential furnaces for the warehouse and office, a heat exchange ventilator, a high-efficiency direct-vent water heater, and a Lennox air conditioner rated at SEER 19. Passive solar heating means the office furnace is rarely used.

The perimeter walls of the 3,000sf retail/office portion are steel stud insulated with sprayed urethane foam providing an R-30 value, compared to R-12 required by the Canadian National Energy Code in this instance. The warehouse walls have a similar R value achieved with pre-fabricated structural insulated panels detailed with double-gasketed rain screen joints supplied by Coldmatic. The roof consists of parallel chord steel trusses and metal roof deck surmounted by two layers of 50mm rigid insulation [100 mm total, R-25], fibreboard, and roof membrane.

Large expanses of glazing maximize solar gain in winter at the south-facing front facade. Exterior sun screens for summer shading were made in a local welding shop using commercially available louvers

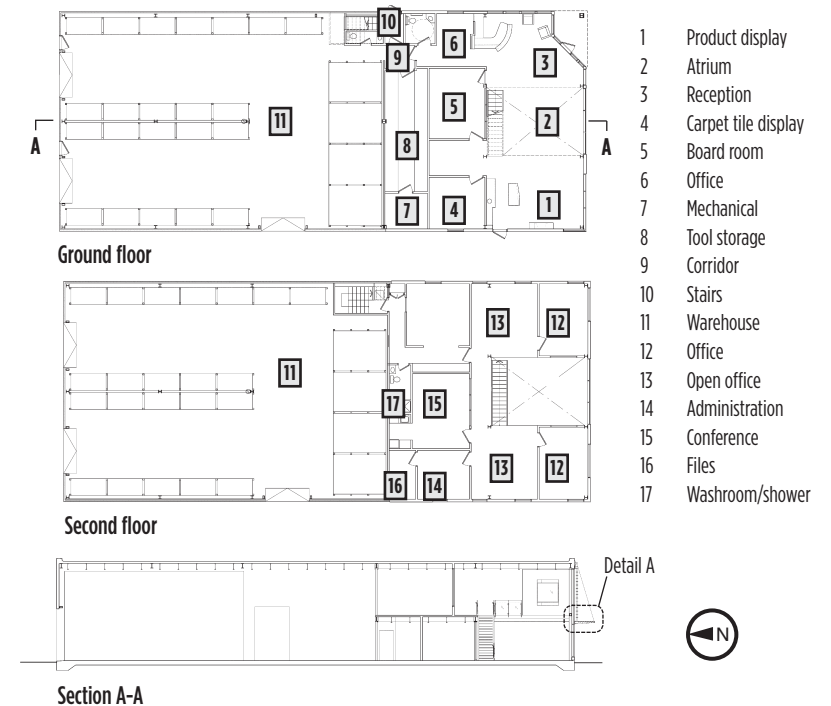



LIGHT STREAMING THROUGH THE LARGE SOUTH WINDOW, BRACED FOR LATERAL RIGIDITY, REDUCES HEATING REQUIREMENTS AND CREATES A VIBRANT INDOOR ENVIRONMENT [5]. THE VIEW OPPOSITE PHOTO 5, NOTE HOW THE INTERIOR OFFICE WINDOW ANGLES TO CATCH THE NATURAL LIGHT [6].

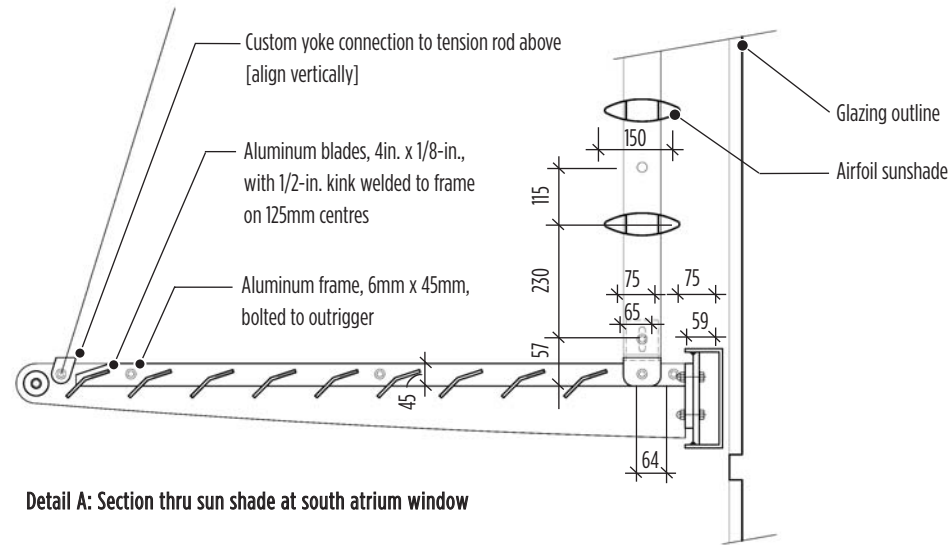

Detail A: Section thru sun shade at south atrium window



6

from Industrial Louvres. Winter heat gain is being monitored to determine the effectiveness of transferring excess heat to the warehouse through a heat pump.

Plans for exterior sun shades for the smaller windows on the east and west facades were dropped in favour of less expensive interior pull-down shades. However, some of the west windows are, in any case, shaded by a neighbouring building, something to consider and benefit from when planing infill buildings.

West and east facade windows, however, are low E, argon-filled, triple-glazed units in thermally broken aluminum frames. Again, to save money, the more sheltered south-facing windows are only double glazed. The aluminum main entry door by Alumaticorp also has a thermal break, a step above compared to regular entry doors.

Flourescent lights, T5 for the warehouse and T8 for the office, have daylight and occupancy sensors to save energy. The T5's provide a more concentrated light for the warehouse compared to the T8's in the office.

Interior finishing was minimized through the use of medium density fibreboard [MDF] and bamboo cabinetry, natural stone, cork and low-VOC Interface carpet tiles, painted drywall as fire protection for the steel wall

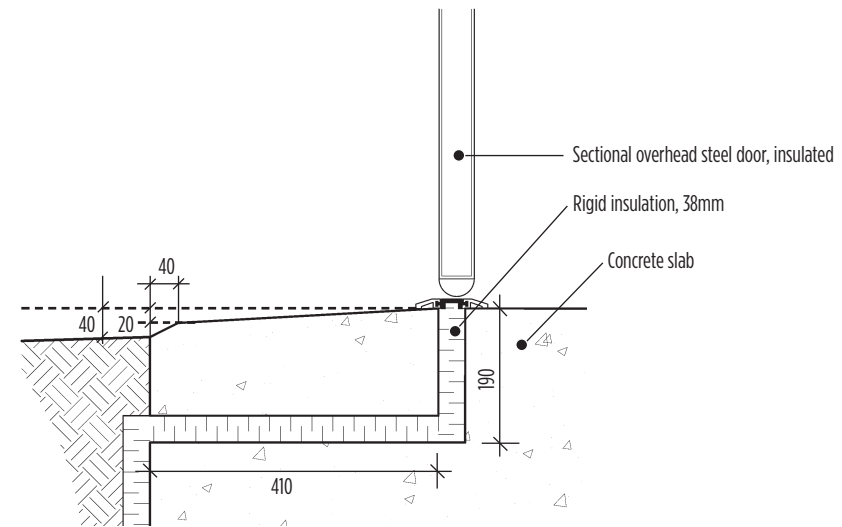

Insulation of slab at warehouse door to prevent frost penetration

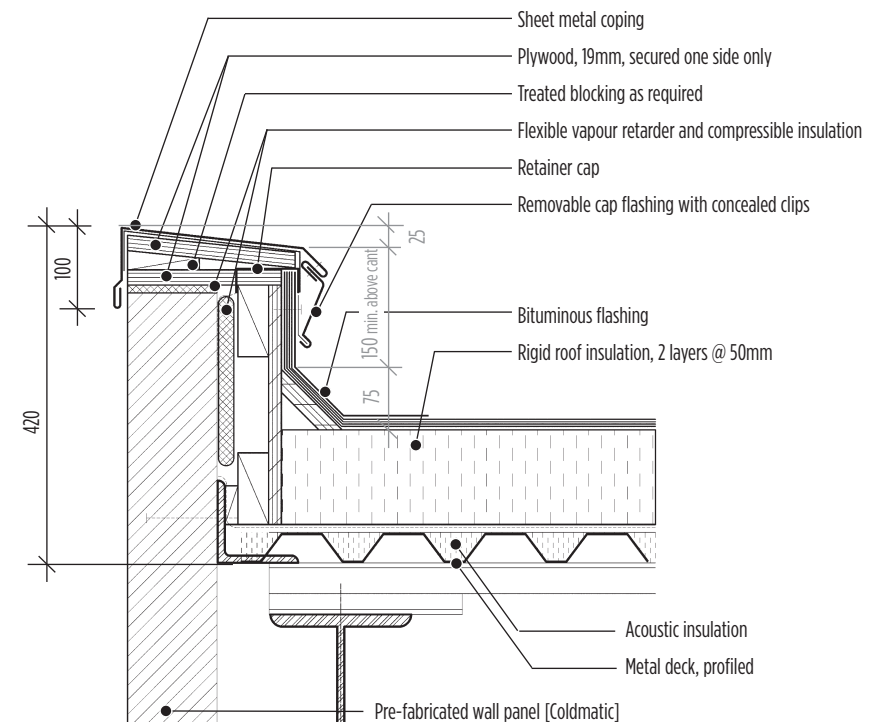

Warehouse wall at roof parapet

studs, and exposed steel floor-ceiling trusses supporting an exposed metal deck that reflects light and has perforations for sound dampening.

We can only concur with construction manager Roy Nandram that products for green building are readily available, and are often off-the-shelf items. It is more the early and regular consultation between the architect, owner, contractor and engineers to plan and implement the most appropriate details,

that achieves the desired result. The Ottawa Citizen's annual review of architecture cited the project as one of the best buildings of 2005. ◀

CHRISTOPHER SIMMONDS IS PRINCIPAL OF CHRISTOPHER SIMMONDS ARCHITECT, AN OTTAWA-BASED PRACTICE FOCUSED AROUND HOLISTIC DESIGN AND ENVIRONMENTAL SUSTAINABILITY.



7

THE EXPOSED STEEL STRUCTURE MINIMIZES FINISHES AND DIVERTS ATTENTION TO THE INTERFACE FLOOR COVERING. THE METAL DECK REFLECTS NATURAL LIGHT AND HAS PERFORATIONS FOR SOUND DAMPENING [7].

#### MATERIALS

- Light steel framing of 102mm or 64mm studs and exposed parallel chord trusses with poured slab construction;
- moisture barrier, sprayed polyurethane foam 75mm, vapour barrier, gypsum board;
- corrugated steel cladding 22mm, or fibre cement panels 8mm, or wood siding 19mm x 64mm, all on 19mm wood strapping;
- warehouse walls prefabricated R30 insulated, double gasket rain screen joints by Thermawall.
- roof of parallel chord steel trusses and metal roof deck surmounted by two layers of 50mm rigid insulation [100 mm total, R-25], fibreboard, and roof membrane;
- Lennox residential high-efficiency furnaces, heat exchange ventilator, and air conditioner rated at SEER 19.
- Alumaticorp entry door with thermal break.
- interior of medium density fibreboard [MDF] and bamboo cabinetry, natural stone, cork and low-VOC Interface carpet tiles.

#### CONSTRUCTION COST

\$950,000

#### COST/SF

\$115